

BERNARD J. MOROSCO

CONSULTING, TRAINING & INSPECTION SERVICES

SAMPLE FOR VIEWING
ONLY

Basic Housing Maintenance Mechanic

(PUBLIC HOUSING)

EXAMINATION

• 1603 Girard Street, Utica, New York 13501-3305 •
PHONE (315) 794-0825 • FAX (425) 962-5854
bernie1603@aol.com

www.morosco.org



License Agreement

Please read this License Agreement before using any of the products attached or provided with this package. By printing, downloading and/or paying for this document, you are agreeing to be bound by the terms of the applicable license agreement.

License. The examination forms are licensed to your agency or company by BERNARD J. MOROSCO. The examination forms are protected under copyright laws of the United States and shall remain the intellectual property of BERNARD J. MOROSCO and/or its suppliers. This License grants to you a non-exclusive rights to use the examination forms for your agency or company use only and may not be distributed or used outside your organization. Your agency or company may photocopy or print unlimited copies for its own purposes within the agency or company ONLY.

Termination. This License shall remain in full force and effect unless and until terminated. This License will terminate immediately, automatically and without notice if you fail to comply with any provision of this agreement. Upon termination, you must stop using the inspection forms, erase or destroy all copies forms and destroy all printed information provided with the this agreement.

Limitation of Liability. IN NO EVENT WILL BERNARD J. MOROSCO OR ITS SUPPLIERS BE LIABLE FOR ANY SPECIAL, CONSEQUENTIAL, INCIDENTAL OR INDIRECT DAMAGES (INCLUDING WITHOUT LIMITATION LOSS OF PROFIT) ARISING OUT OF YOUR USE OR INABILITY TO USE THIS PRINTED INFORMATION CONTAINED HEREIN, WHETHER OR NOT AUTHOR HAS BEEN ADVISED OF THE POSSIBILITY OF SUCH LOSS, HOWEVER CAUSED AND ON ANY THEORY OF LIABILITY. THIS EXCLUSION INCLUDES ANY LIABILITY THAT MAY ARISE OUT OF THIRD-PARTY CLAIMS AGAINST YOU. THESE LIMITATIONS SHALL APPLY NOTWITHSTANDING ANY FAILURE OF ESSENTIAL PURPOSE OF ANY LIMITED REMEDY.

Entire Agreement. This agreement constitutes the entire agreement between your agency or company and BERNARD J. MOROSCO and supersedes any other prior agreements or communications regarding the training and documentation and forms provided. If any provision of this agreement is held invalid, the remainder of this agreement shall continue in effect.

SAMPLE FOR VIEWING ONLY

SAMPLE FOR VIEWING ONLY

1. a **pipe wrench** is a tool best associated with which type of repair
 - a. carpentry
 - b. plumbing
 - c. electrical
 - d. masonry

2. **HVAC** is a term that stands for
 - a. Heating, Ventilating Alternating Current
 - b. Holistic Vacuum Air Conditioner
 - c. Heating Ventilation and Air Conditioning
 - d. High Voltage with Air Conditioning

3. Water on the floor below or near a Hot Water Heater is a **potential** indicator of
 - a. Flooding basement
 - b. Leaking Hot Water tank
 - c. Leaking TPR Valve
 - d. Both B. and/or C.

4. A **Phillips screwdriver** had what type of pattern
 - a. -
 - b. x

SAMPLE FOR VIEWING ONLY

5. The term **pilot light** is best associated with which type of appliance
 - a. Air Conditioner
 - b. Recirculating Fan
 - c. Stove
 - d. None of the above

6. The acronym **GFCI** Stands for
 - a. Grounded full circuit interconnector
 - b. Grounded fault challenge interpolator
 - c. Ground Fault Circuit Interruptor
 - d. Ground filled construction instep

7. The term **MERV Rating** is best associated with
 - a. Water density
 - b. Hot Water Heater BTU output
 - c. HVAC Air Filtration
 - d. Plumbing fixtures

8. The term **Low Water Cutoff** is best associated with
 - a. HVAC Systems
 - b. Hot Water Tanks
 - c. Boilers
 - d. Evaporators

9. Proper installation of dryer venting should be done utilizing
 - a. International Building Code
 - b. New York State Uniform Fire Prevention and Building Code
 - c. NFPA 74
 - d. Manufacture's Instructions

10. How many steps are required on a set of stairs in order to have a handrail required to be installed?
 - a. 3
 - b. 4
 - c. 5
 - d. 2

Match Up Questions 11 – 14 with the column on the right

- | | |
|---|--|
| 11. Single Station Smoke Alarm _____ | A. Air delivered to a conditioned space through ducts or plenums from the heat exchanger of a heating, cooling or ventilating system. |
| 12. Water Distribution System _____ | B. Piping which conveys water from the service to the plumbing fixtures, appliances, appurtenances, equipment, devices or other systems served, including fittings and control valves. |
| 13. Supply Air _____ | C. An assembly incorporating the detector, control equipment and alarm sounding device in one unit that is operated from a power supply either in the unit or obtained at the point of installation. |
| 14. Temperature Pressure Relief valve _____ | |

SAMPLE FOR VIEWING ONLY

spring or other pressure at the

20. The Diagram to the right depicts one face of a chimney, No bricks were cut to form the chimney; the "half-bricks" are the end bricks that extend along one of the sides. How many bricks are needed to build the entire chimney?
 - a. 28
 - b. 30
 - c. 32
 - d. 34

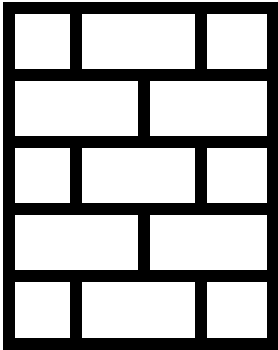

21. The term "**square**" is an area measurement best known in which construction area
 - a. Masonry
 - b. Electrical
 - c. Roofing
 - d. Plumbing

22. **Rebar** is utilized in
 - a. Electrical wiring

- b. Pipefitting repairs
- c. Foundation construction
- d. HVAC Support

23. Looking at the photo on the right, which door handle would you utilize in a unit required for handicap access?

- a. The top drawing
- b. The bottom drawing
- c. Either would qualify

24. Hollow-core doors are best utilized where?

- a. Apartment entry doorways
- b. Interior (bedroom) doorways
- c. Bathroom doorways
- d. Any of the above

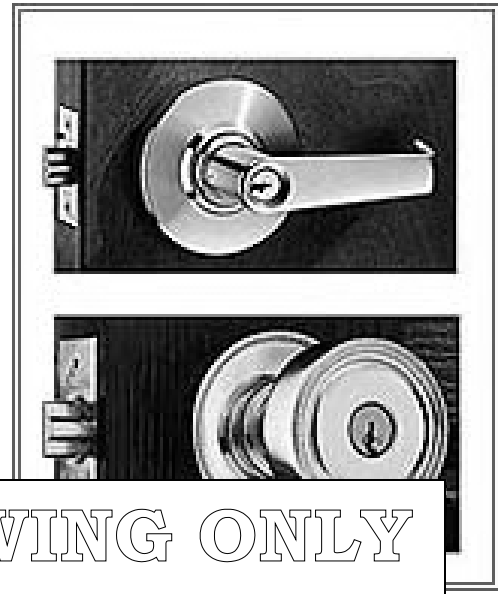

SAMPLE FOR VIEWING ONLY

Identify the parts of a toilet from the diagram listing the letter in the appropriate question

- 25. Filler Valve _____
- 26. Flush Valve _____
- 27. Rim _____
- 28. Filler Float _____
- 29. Siphon _____
- 30. Handle _____
- 31. Overflow Tube _____
- 32. Tank _____
- 33. Bowl _____

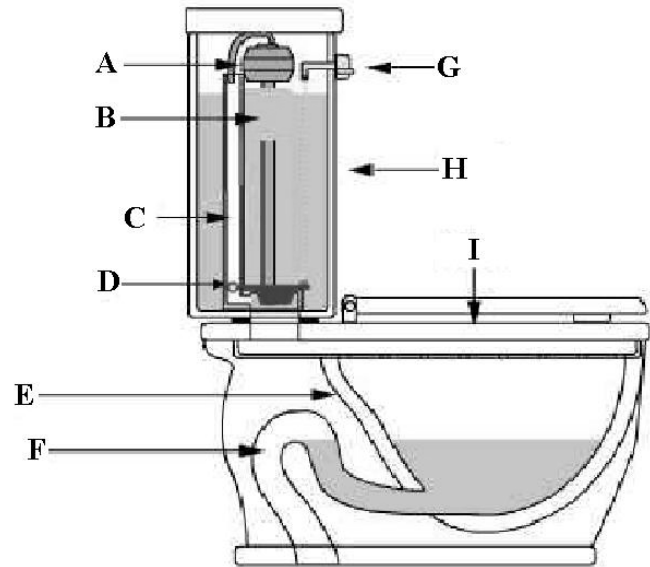

34. Many Smoke Detectors installed today are “hard wired” to the household electrical system but still have a 9 volt battery
- True
 - False
35. The term “**Lintel**” is most associated with
- Windows and Doors
 - Walls and Ceilings
 - Floors and Ceiling
 - Doors and Walls
36. **Formica** is usually seen in what building component?
- Floors
 - Ceilings
 - Cabinets
 - Countertops
37. The “optimal” output temperature for residential hot water heaters is most commonly considered to be? (in farenheit)

a. 115 degrees

SAMPLE FOR VIEWING ONLY

38. It is generally accepted that mechanical or natural ventilation is required in which area of a residential unit?
- Kitchens and Bathrooms
 - Kitchens only
 - Bathrooms only
 - Laundry Rooms
39. Mildew is **most commonly** associated with which room in a residence?
- Laundry Rooms
 - Kitchens
 - Bathrooms
 - Basements
40. **Gypsum** (Hydrated Calcium Sulfate) is best associated with which building component?
- Floors
 - Walls
 - Doors
 - Ceilings and Walls
41. The term **WD-40** is best associated with
- Wall board
 - Lubricating Oil
 - Sandpaper grade
 - Concrete type

42. **Boric Acid** is a product best used for what area?
- a. Concrete hardening
 - b. Sidewalk cleaning
 - c. Insect control
 - d. Mold control
43. The term **3 Tab** is generally part of what building component
- a. masonry blocks
 - b. roof shingles
 - c. porch flooring
 - d. hardwood floors
109. A "**spongy**" floor is a good indicator of
- a. an older house
 - b. a rotted subfloor

SAMPLE FOR VIEWING ONLY